

GOSSEN
Eriangen

Sole U. S. Distributor:
KLING PHOTO CORPORATION
New York Los Angeles
GOSSEN T. M. Reg. U S. Pat Off. Printed in Germany

2682 a



GOSSEN

Variable Angle
Attachment for
LUNA-PRO

TELE

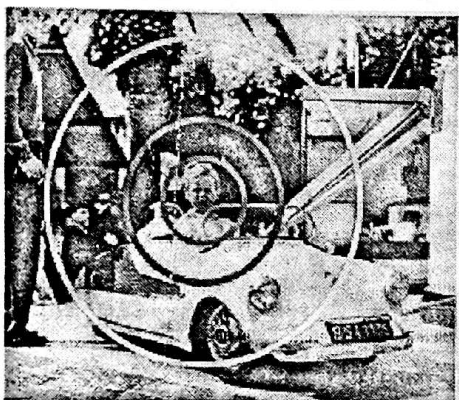

The TELE Attachment enables you to reduce the normal (30°) measuring angle of your LUNA-PRO either to 15° or even 7.5°. The built-in reflex viewfinder shows you the area to be measured.

The illustration at the left shows the three measuring fields of your LUNA-PRO, viewed from the same distance. (The yellow circle which delineates the full 30° measuring field is, of course, not in the viewfinder). The following instructions assume that you are familiar with the regular operation of the LUNA-PRO itself.

The limitation of the measuring angle by means of the TELE Attachment to either 15° or 7.5° permits a more refined measuring technique: When using long telephoto lenses you can adapt

view by comparing the viewfinder image of the TELE Attachment with that of your camera viewfinder.

Selective Readings - the smaller measuring angles permit the targeting of the measurement to selected important spots within your subject.

Contrast - you can get a definite idea of the contrast prevailing in the subject by measuring the lightest and the darkest areas individually. Should the prevailing contrast exceed the capabilities of the film used, the shadow portions may be lightened by means of reflectors or by flash.

Mounting the Attachment
Slide the hemispheric diffuser of the LUNA-PRO

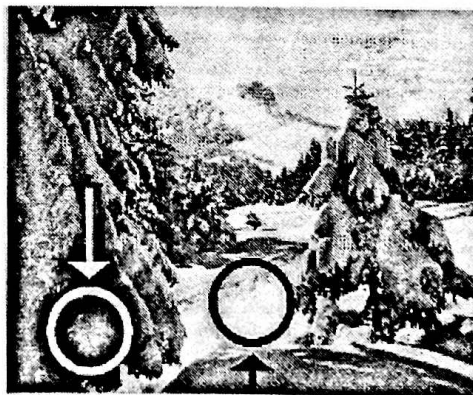

to the right. Insert the lug (6) of the TELE Attachment into the slot provided in the LUNA-PRO housing; the diffuser will fit into the recess of the Attachment. Now press the button (5) and fit the Attachment entirely on the LUNA-PRO. Releasing the button will fix the Attachment firmly on the meter.

Angle Selector slide

The measuring angle is selected by means of the black slide (4). When you shift slide all the way to the left, the measuring angle set is 15°; at the left of the slide "15°" and a red symbol will appear. When the slide is shifted all the way to the right, the 7.5° measuring angle is set; at the right "7.5°" and a green symbol will appear. Always make sure that the selector

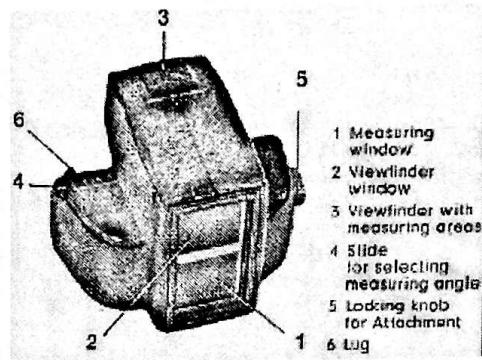

slide is shifted all the way to the left or right until it clicks into position; otherwise incorrect readings might result.

Measuring - proceed as you would in using your LUNA-PRO for regular reflected light readings - merely with the following modifications:

1. Use the reflex viewfinder for aiming the meter. The area you see within the larger (red) circle is being measured when the Selector Slide is set to 15°; the smaller (green) circle corresponds to the 7.5° measuring angle.
2. Read the needle deflection on the indicator scales of the LUNA-PRO in the usual manner but, instead of transferring the reading to the triangular index of the yellow transfer scale,

set a 15° reading to the red circle index, a 7.5° reading to the green circle index of the transfer scale.

The color coding facilitates correct settings:
red for 15°. green for 7.5°.

Suggestions for selective measurements:

Which portions of a subject should you measure so that the LUNA-PRO will indicate the "correct" exposure time - the lightest or the darkest areas? The answer is: Neither! Spot readings of areas of average brightness - preferably a medium grey - will usually produce good results. Please bear in mind that the lightest areas may be lighter by four or more steps (i. e. at least 16 times) than the darkest portions. Measurement

of the brightest portions would almost certainly lead to underexposure, while overexposure would result when based on readings of only the darkest portions. Therefore, the correct exposure lies somewhere between those two extremes; it can be determined by the following method: Set on the transfer scale the middle value between the high and low light area readings. Example: You had obtained a reading of "13" for the darkest portion, and "17" for the lightest portion of the subject. Use the middle value, i.e. "15" and set it at the appropriate index (green or red) on the yellow transfer scale.