

CEN-TECH™

INFRARED THERMOMETER

Model 96451

OPERATING INSTRUCTIONS



Diagrams within this manual may not be drawn proportionally.
Due to continuing improvements, actual product may differ slightly from the product described herein.

Visit our website at: <http://www.harborfreight.com>



Read this material before using this product.
Failure to do so can result in serious injury.
SAVE THIS MANUAL.

Copyright © 2007 by Harbor Freight Tools®. All rights reserved. No portion of this manual or any artwork contained herein may be reproduced in any shape or form without the express written consent of Harbor Freight Tools.

For technical questions or replacement parts, please call 1-800-444-3353.

63011

SAVE THIS MANUAL

Keep this manual for the safety warnings and precautions, assembly, operating, inspection, maintenance and cleaning procedures. Write the product's serial number in the back of the manual near the assembly diagram (or month and year of purchase if product has no number). Keep this manual and the receipt in a safe and dry place for future reference.

WARNING! Read all instructions.
Failure to follow all instructions listed below may result in serious injury.

Work area safety

1. Keep children and bystanders away while operating. Distractions can cause you to lose control.
2. Keep work area clean and well lit. Cluttered or dark areas invite accidents.

Personal safety

1. Wear ANSI-approved safety goggles. Use eye protection. Never point laser directly into the eyes of a person or animal. Do not point laser on, or indirectly off, reflective surfaces such as stainless steel or aluminum.
2. Stay alert and use common sense when operating. Do not use when tired or under the influence of drugs, alcohol or medication.

Product use and care

1. This product is not a toy. Keep it out of reach of children.
2. Use the product in accordance with these instructions and in the manner intended for the particular type of product, taking into account the working conditions and the work to be performed. Use of the product for operations different from those intended could result in a hazardous situation.
3. Not for medical use.
4. The warnings, precautions, and instructions discussed in this instruction manual cannot cover all possible conditions and situations that may occur. It must be understood by the operator that common sense and caution are factors which cannot be built into this product, but must be supplied by the operator.

Service

1. Have product serviced by a qualified repair person using only identical replacement parts. This will ensure that the safety of the product is maintained.

2. Maintain labels and nameplates on the product. These carry important safety information. If unreadable or missing, contact Harbor Freight Tools for a replacement.



SAVE THESE INSTRUCTIONS.

SPECIFICATIONS

Measurement Range	-4° F to 968° F (-20° C to 520° C)
Accuracy	± 4° F below 212° F ± 2% reading above 212° F
Response Time	500 mSec
Distance to Spot Size	8:1
Battery Requirements	9V



UNPACKING

When unpacking, check to make sure that the item is intact and undamaged. If any parts are missing or broken, please call Harbor Freight Tools at the number shown on the cover of this manual as soon as possible.

OPERATING INSTRUCTIONS



Read the **ENTIRE IMPORTANT SAFETY INFORMATION** section at the beginning of this manual including all text under subheadings therein before set up or use of this product.

Note: Do not expose this product to strong electromagnetic fields, such as those generated by an arc welder, induction heater, etc. Allow the unit 30 minutes to adjust, before use, when introduced to significant temperature changes.

1. Remove the battery cover and insert a 9V battery into the unit, paying attention to polarity. Replace battery cover.
2. Push the "Laser ON/OFF" button to activate unit.
3. Pull and hold down trigger to turn unit on. When the Trigger is released, the unit will beep and display the last temperature measured for 15 seconds.
4. To locate a "hot spot" move laser up and down in an area to see temperature variance.
5. Non-reflective surfaces will yield a more accurate reading than reflective surfaces. Duct tape (not included) can be applied to reflective surfaces in order

to get a better measurement. Allow sufficient time for the tape to match the temperature of the surface it is applied to before trying to get a reading.

- The maximum range for the Infrared Thermometer is about 8 feet. The object being tested should be larger than the size calculated by the field of view diagram, below

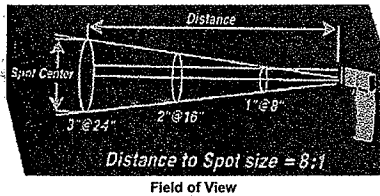

- Push the °F/°C button to toggle from Fahrenheit to Celsius.
- Clean the lens with dry compressed air and wipe the rest of the unit down with a soft, damp cloth, then store the product indoors out of children's reach.

MAINTENANCE AND SERVICING

CAUTION Damaged products can fail, causing personal injury. Do not use a damaged product. If abnormal noise or vibration occurs, have the problem corrected before further use.

Cleaning, maintenance, and lubrication

- BEFORE EACH USE**, inspect the general condition of the product. Check for loose screws, misalignment or binding of moving parts, cracked or broken parts, and any other condition that may affect its safe operation.
- AFTER USE**, clean external surfaces of the product with clean, moist cloth.

SKU 96451 For technical questions, please call 1-800-444-3353. Page 4

PLEASE READ THE FOLLOWING CAREFULLY

THE MANUFACTURER AND/OR DISTRIBUTOR HAS PROVIDED THE PARTS LIST AND ASSEMBLY DIAGRAM IN THIS MANUAL AS A REFERENCE TOOL ONLY. NEITHER THE MANUFACTURER OR DISTRIBUTOR MAKES ANY REPRESENTATION OR WARRANTY OF ANY KIND TO THE BUYER THAT HE OR SHE IS QUALIFIED TO MAKE ANY REPAIRS TO THE PRODUCT, OR THAT HE OR SHE IS QUALIFIED TO REPLACE ANY PARTS OF THE PRODUCT. IN FACT, THE MANUFACTURER AND/OR DISTRIBUTOR EXPRESSLY STATES THAT ALL REPAIRS AND PARTS REPLACEMENTS SHOULD BE UNDERTAKEN BY CERTIFIED AND LICENSED TECHNICIANS, AND NOT BY THE BUYER. THE BUYER ASSUMES ALL RISK AND LIABILITY ARISING OUT OF HIS OR HER REPAIRS TO THE ORIGINAL PRODUCT OR REPLACEMENT PARTS THERETO, OR ARISING OUT OF HIS OR HER INSTALLATION OF REPLACEMENT PARTS THERETO.

PARTS LIST

Part	Description	Qty	Part	Description	Qty
1	Handle Case	1	14	Receiving Housing	1
2	Left Cover	1	15	LCD	1
3	Right Cover	1	16	Laser Set	1
4	Battery Cover	1	17	Conductive Rubber	1
5	Opening Hood	1	18	Screw	8
6	Trigger	1	19	Tape	1
7	Receiving Tube	1	20	Battery Connector	2
8	Backlight Board	1	21	Spring	1
9	Right Button	1	22	Black Rubber	2
10	Left Button	1	23	Sponge Mat	1
11	Aluminum Receiving Tube	1	24	Battery	1
12	Aluminum Lens Tube	1	25	Panel Label	1
13	Sensor Lens	1	26	PCB	1

SKU 96451 For technical questions, please call 1-800-444-3353. Page 5

ASSEMBLY DIAGRAM

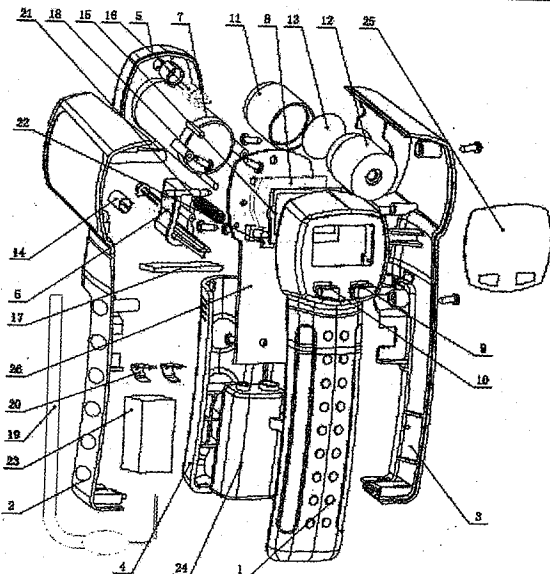

Record Product's Serial Number Here: _____

Note: If product has no serial number, record month and year of purchase instead.

Note: Some parts are listed and shown for illustration purposes only, and are not available individually as replacement parts.

SKU 96451 For technical questions, please call 1-800-444-3353. Page 6

LIMITED 1 YEAR WARRANTY

Harbor Freight Tools Co. makes every effort to assure that its products meet high quality and durability standards, and warrants to the original purchaser that this product is free from defects in materials and workmanship for the period of one year from the date of purchase (90 days if used by a professional contractor or if used as rental equipment). This warranty does not apply to damage due directly or indirectly, to misuse, abuse, negligence or accidents, repairs or alterations outside our facilities, normal wear and tear, or to lack of maintenance. We shall in no event be liable for death, injuries to persons or property, or for incidental, contingent, special or consequential damages arising from the use of our product. Some states do not allow the exclusion or limitation of incidental or consequential damages, so the above limitation of exclusion may not apply to you. THIS WARRANTY IS EXPRESSLY IN LIEU OF ALL OTHER WARRANTIES, EXPRESS OR IMPLIED, INCLUDING THE WARRANTIES OF MERCHANTABILITY AND FITNESS.

To take advantage of this warranty, the product or part must be returned to us with transportation charges prepaid. Proof of purchase date and an explanation of the complaint must accompany the merchandise. If our inspection verifies the defect, we will either repair or replace the product at our election or we may elect to refund the purchase price if we cannot readily and quickly provide you with a replacement. We will return repaired products at our expense, but if we determine there is no defect, or that the defect resulted from causes not within the scope of our warranty, then you must bear the cost of returning the product.

This warranty gives you specific legal rights and you may also have other rights which vary from state to state.

3491 Mission Oaks Blvd. • PO Box 6009 • Camarillo, CA 93011 • (800) 444-3353

SKU 96451 For technical questions, please call 1-800-444-3353. Page 7